



## **Setting New Standards in Laboratory & Industrial Weighing— The Next Generation of Scout Balances**

Ideal for laboratory & industrial applications, the OHAUS Scout features an easy to navigate color touchscreen display & a slim design which allows stackable storage. Geared for superior performance with fast stabilization time and high resolution weighing results, these portable balances set a new standard for a broad range of weighing applications. Features also include superior overload protection and expanded connectivity options.

### **Standard Features Include:**

- **Quick and Efficient Navigation with the Informative Color Touchscreen Display**  
Large, resilient color touchscreen allows for effortless operation of the Scout through its informative icon driven menu structure, guiding the user through every step of the weighing application.
- **Fast Weighing Speed and High Resolution Deliver Repeatable and Reliable Results**  
Stabilization time as fast as 1 sec means increased productivity in your facility. Equipped with advanced weighing technology, the Scout also ensures repeatable and reliable weighing results.
- **Superior Overload Protection & Stackable Storage Drive Overall Durability**  
Integrated superior overload protection system rated at 10 times the capacity protects the balance in rugged and demanding environments. The space-saving, slim design allows for stackable storage.
- **Multiple Connectivity Options for Greater Flexibility in Communication**  
With expanded connectivity options including RS232, USB Host, USB Device, Ethernet and Bluetooth<sup>®</sup>, the Scout provides added versatility to your data collection and transfer needs.

# Scout® Portable Balances

## Navigate and Operate the Balance Easily with the Informative Touchscreen Display

Portable balance operation has never been easier, faster or as intuitive as the new OHAUS Scout with color touchscreen display. You'll navigate easily through the Scout's resistive touchscreen interface and icon-driven menu structure, maneuver efficiently in and out of application modes, change weighing units with a simple press of the screen and execute setup and calibration functions in no time. The OHAUS Scout with color touchscreen display creates a new level of unmatched efficiency and functionality in portable weighing.

A real-time clock function keeps accurate time even during power loss. Additionally, GLP/GMP tracking capabilities assist in the monitoring and reporting of data.

## Increased Efficiency and Productivity in your Facility

It's all about accuracy and efficiency with the OHAUS Scout Touchscreen balance. Stabilization time as fast as 1 sec means increased productivity in the lab, or on the line. With improved resolution, you can count on extremely precise and repeatable weighing results time and time again.

## Scout's Signature Durability Remains Unrivaled

You would expect nothing less from OHAUS than the most durable portable weighing product - that's why we've included our superior overload protection rated at 10 times the capacity of the balance, high strength stainless steel pan, impact-resistant pan support and integrated transportation/storage lock. We've even ensured that the high quality, resistive touchscreen is built to last. To complement our signature durability, the Scout Touchscreen is designed to be stackable when utilizing the included stacking and storage cover, which also protects the balance when not in use.

## Versatile Data Collection and Transfer

With expanded connectivity options now featuring Bluetooth®, the OHAUS Scout offers more versatility for convenient data logging, communication and remote functionality. Utilize the Bluetooth® accessory to remotely control the balance from your mobile device or tablet for Android™\*\*. Perform functions such as Zero, Tare, Print, Power Off and more. Other accessories include RS232, USB Device, USB Host and Ethernet. With the USB Host option, you can simply save and transfer data from the balance to a USB drive.

## Draftshield Model Available

Scout's ingenious draftshield (1mg models only) was designed with an easy to remove top cover piece. This serves as a wind protection ring which keeps the weighing surface stable in rough environments, while maintaining weighing speed.

\*The Bluetooth word mark and logos are registered trademarks owned by Bluetooth SIG, Inc. and any use of such marks by OHAUS is under license.

\*\*Android is a trademark of Google Inc.

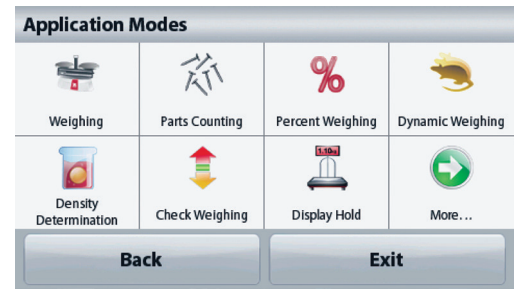



**Draftshield**  
Protects the sample from external influences, increasing the speed and repeatability of measurements



**Connectivity**  
Expanded connectivity options including RS232, USB Host, USB Device, Ethernet and Bluetooth®



**Weigh Below Hook**  
The integral weigh below hook on the bottom of the Scout allows for density determination or specific gravity calculations



**Security Slot**  
Integrated security slot prevents theft

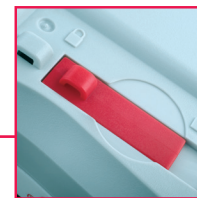

**Lockswitch**  
The Scout can be locked into a specific configuration using the lockswitch

**Color Touch Screen Display**  
Informative icon-driven touchscreen display for easy navigation

## Capacity & Readability by Weighing Unit

Model	STX123	STX223	STX222	STX422	STX622	STX1202	STX2202	STX421	STX621	STX2201	STX6201	STX8200
Gram (g)	120 × 0.001	220 × 0.001	220 × 0.01	420 × 0.01	620 × 0.01	1200 × 0.01	2200 × 0.01	420 × 0.1	620 × 0.1	2200 × 0.1	6200 × 0.1	8200 × 1
Kilogram (kg)	/	/	/	/	/	1.2 × 0.00001	2.2 × 0.00001	/	/	2.2 × 0.0001	6.2 × 0.0001	8.2 × 0.001
Carat (ct)	600 × 0.005	1100 × 0.005	1100 × 0.05	2100 × 0.05	3100 × 0.05	6000 × 0.05	11000 × 0.05	2100 × 0.5	3100 × 0.5	11000 × 0.5	31000 × 0.5	41000 × 5
Newton (N)	1.17679 × 0.00001	2.15744 × 0.00001	2.1574 × 0.0001	4.1188 × 0.0001	6.0801 × 0.0001	11.7679 × 0.0001	21.5744 × 0.0001	4.119 × 0.001	6.080 × 0.001	21.574 × 0.001	60.801 × 0.001	80.41 × 0.01
Ounce (oz)	4.23290 × 0.00005	7.76030 × 0.00005	7.7600 × 0.0005	14.8150 × 0.0005	21.8700 × 0.0005	42.3290 × 0.0005	77.6030 × 0.0005	14.815 × 0.005	21.870 × 0.005	77.600 × 0.005	218.700 × 0.005	289.25 × 0.05
Ounce Troy (ozt)	3.85810 × 0.00005	7.07320 × 0.00005	7.0730 × 0.0005	13.5030 × 0.0005	19.9335 × 0.0005	38.5810 × 0.0005	70.7320 × 0.0005	13.500 × 0.005	19.930 × 0.005	70.730 × 0.005	199.335 × 0.005	263.60 × 0.05
Pennyweight (dwt)	77.162 × 0.001	141.463 × 0.001	141.46 × 0.01	270.07 × 0.01	398.67 × 0.01	771.62 × 0.01	1414.63 × 0.01	270.1 × 0.1	398.7 × 0.1	1414.6 × 0.1	3986.7 × 0.1	5270 × 1
Pound (lb)	/	/	/	/	1.36690 × 0.00005	2.64555 × 0.00005	4.85020 × 0.00005	/	1.3670 × 0.0005	4.8500 × 0.0005	13.6685 × 0.0005	18.080 × 0.005
Pound:Ounce (lb:oz)	/	/	/	/	1lb:5.8700oz × 0.0005oz	2lb:10.3290oz × 0.0005oz	4lb:13.6030oz × 0.0005oz	/	1lb:5.870oz × 0.005oz	4lb:13.600oz × 0.005oz	13lb:10.700oz × 0.005oz	18lb:1.25oz × 0.05oz
Grain (grn)	1851.88 × 0.02	3395.12 × 0.02	3395.0 × 0.2	6481.6 × 0.2	9568.0 × 0.2	18518.8 × 0.2	33951.2 × 0.2	6480 × 2	9570 × 2	33950 × 2	95680 × 2	126540 × 20

## Outline Dimensions

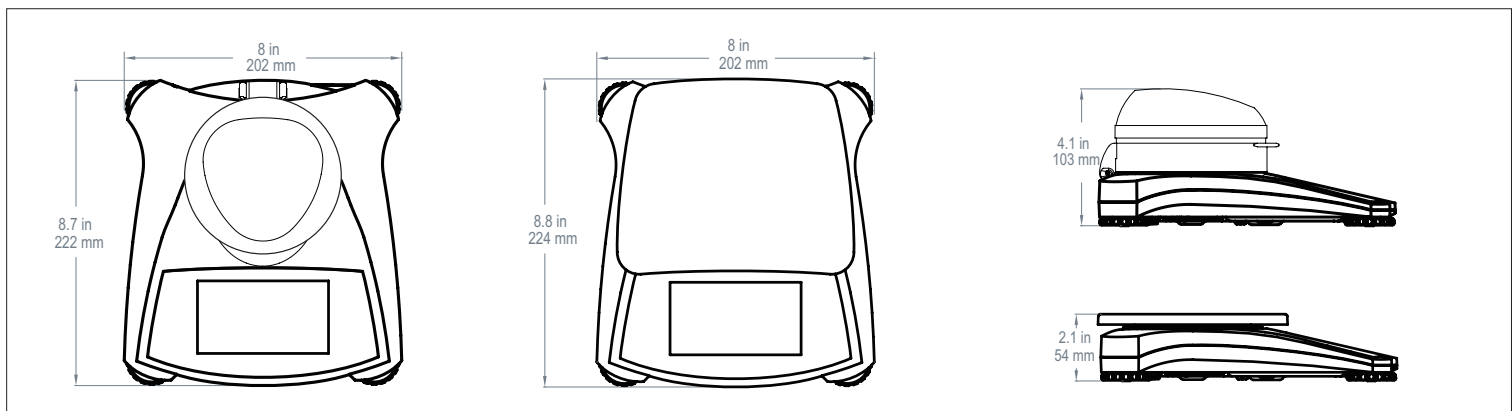

# Scout® Portable Balances

Model	STX123	STX223	STX222	STX422	STX622	STX1202	STX2202	STX421	STX621	STX2201	STX6201	STX8200
Capacity (g)	120	220	220	420	620	1200	2200	420	620	2200	6200	8200
Readability (g)	0.001	0.001	0.01	0.01	0.01	0.01	0.01	0.1	0.1	0.1	0.1	1
Repeatability (Std. Dev.) (g)	0.002	0.002	0.01	0.01	0.01	0.02	0.02	0.1	0.1	0.1	0.1	1
Linearity (g)	0.003	0.003	0.01	0.01	0.02	0.03	0.03	0.1	0.1	0.1	0.2	1
Span Calibration Mass <sup>1</sup>	100 g	200 g	200 g	200 g	300 g	1 kg	2 kg	200 g	300 g	2 kg	5 kg	8 kg
Linearity Calibration Mass	50, 100 g	100, 200 g	100, 200 g	200, 400 g	300, 600 g	500 g, 1 kg	1 kg, 2 kg	200, 400 g	300, 600 g	1 kg, 2 kg	3 kg, 6 kg	4 kg, 8 kg
Stabilization Time (s)	1.5	1.5	1	1	1	1.5	1.5	1	1	1	1	1
Construction	ABS housing & stainless steel pan											
Draftshield	Yes			No								
Calibration	User-selectable external span or linearity calibration/Digital with external weight											
Tare Range	Full capacity by subtraction											
Weighing Units <sup>2</sup>	mg, g, kg, ct, N, oz, ozt, dwt, lb, lb:oz, grn, hkt, sgt, twt, tical, tola, customer unit 1											
Application Modes	Weighing, Parts Counting, Percent Weighing, Check Weighing, Animal/Dynamic Weighing, Totalization, Density Determination, Display Hold, Mole Weighing											
Power Requirement	AC adapter (included) or 4 AA batteries (not included)											
Typical Battery Life	6 hours											
Communication	RS232, USB Host, USB Device, Ethernet or Bluetooth® (available as an accessory)											
Display Type	4.3" (109 mm) full-color VGA graphic touchscreen display with user-controlled brightness											
Display Size	4.3 in/109 mm (diagonal)											
Overload Capacity	10 times the rated capacity											
Operating Temperature Range	50°F/10°C to 104°F/40°C at 10% to 80% relative humidity, non-condensing											
Storage Conditions	-20°C (-4°F) to 55°C (131°F) at 10% to 90% relative humidity, non-condensing											
Pan Size (W × D)	Ø3.7 in/ 93 mm		Ø 4.7 in/ 120 mm			6.7 × 5.5 in/ 170 × 140 mm		Ø 4.7 in/ 120 mm		6.7 × 5.5 in/ 170 × 140 mm		
Balance Dimensions (W × D × H)	8 × 8.7 × 4.1 in/ 202 × 222 × 103 mm		8 × 8.8 × 2.1 in/ 202 × 224 × 54 mm									
Shipping Dimensions (W × D × H)	11.8 × 9.8 × 5.1 in/300 × 250 × 129 mm											
Net Weight	2.2 lb/1 kg											
Shipping Weight	3.5 lb/1.6 kg											

<sup>1</sup> Span calibration weight is included with models up to 620g capacity

<sup>2</sup> Availability is dependent on model and region

## Other Standard Features and Equipment

Transportation lock, stainless steel pan, menu & calibration lockout switch, slip-resistant and adjustable feet, leveling bubble, mechanical and software overload/underload protection, stability indicator, auto tare, low battery indicator, auto shut-off, user selectable printing options, user selectable communication settings

## Compliance

- **Product Safety:** IEC/EN 61010-1; CAN/CSA C22.2 No. 61010-1; UL Std. No. 61010-1
- **Electromagnetic Compatibility:** IEC/EN 61326-1 Class B; FCC Part 15 Class B; Industry Canada ICES-003 Class B

## Accessories

RS232 Interface Kit	30268982
USB Host Interface Kit (for Flash Drive)	30268983
USB Device Interface Kit (for PC)	30268984
Bluetooth Interface Kit	30268985
Ethernet Interface Kit	30268986
Stacking & Storage Cover* (6 pcs)	30268987
Stacking & Storage Cover* (1 pc)	30268988
Printer, Impact, SF40A, AM	30064203
Auxiliary Display, AD7-MD	30472063
Security Device	80850043
Top Loading Kit for Density Determination	30269020
Carrying Case	30269021
In-use Cover	30269022
Adapter, 5V 1A US, Fixed Plug	30330714

\*Not fit for models with draftshield

80774941\_G 20181107 © Copyright OHAUS Corporation

**OHAUS CORPORATION**  
7 Campus Drive  
Suite 310  
Parsippany, NJ 07054 USA

Tel: 800.672.7722  
973.377.9000  
Fax: 973.944.7177

[www.ohaus.com](http://www.ohaus.com)

*The management system governing the manufacture of this product is ISO 9001:2015 certified.*

