

# WLC.X2 PRECISION BALANCES

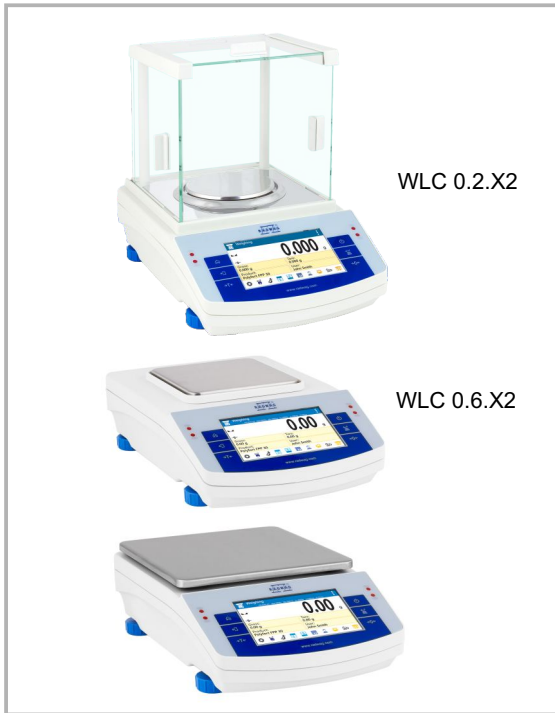



release date 12-08-2016



The **WLC.X2 series** represents a **new advanced level** for precision balances.

The X2 series balances feature the latest generation capacitive display providing the maximum comfort of use, available right at your fingertips. Ease of operation, clear menu and practical arrangement of the display guarantee the best ergonomics for your everyday tasks. A wide array of available interfaces facilitate selection of the most optimal means for communication. The X2 series balances offer unlimited possibilities for cooperation with external devices, providing printing, copying, archiving and data transfer. Built-in IR sensors allow numerous operations (e.g. tarring, transmitting the result to a printer or selecting successive steps of a particular process, etc.) to be performed hands-free, by simply moving a hand across the sensor. The housing is made of plastic, and the pan is made of stainless steel.

The balances feature under-pan weighing option - the weighed load is suspended under the balance.

-  Parts counting
-  Dosing
-  Checkweighing
-  Formulation
-  Percent deviations
-  Statistics
-  Animal weighing
-  Autotest (GLP, Filter)
-  Density determination
-  GLP procedures
-  Under hook weighing
-  Peak hold
-  Infrared sensors
-  Ambient conditions monitoring
-  Newton unit measurement
-  Replaceable units
-  ALIBI Memory

## DATABASES IN X2 SERIES BALANCES

In new WLC.X2 series balances the information system is based on 7 databases, which allows for several users to work with several products databases, and the registered weighing results can be subject to further analysis.

### The data is registered in 7 databases:

- Users (up to 100 users),
- Products (up to 5 000 products),
- Weighments (up to 50 000 weighments),
- Packaging (up to 100 packaging types),
- Formulas (up to 100 formulas),
- Clients (up to 100 clients),
- ALIBI memory (up to 500 000 weighments).

### The X2 series features option of making reports of 2 different categories:

- Reports on formulas (up to 200 reports),
- Reports on density determination (up to 500 reports).

## Technical specification:

	WLC 0.2.X2	WLC 0,6.X2	WLC 2.X2	WLC 6.X2	WLC 1/10.X2	WLC 10.X2	WLC 20.X2	WLC 21.X2
Max capacity	0,2 kg	0,6 kg	2 kg	6 kg	1 kg / 10 kg	10 kg	20 kg	21 kg
Readability [d]	0,001 g	0,01 g	0,01 g	0,1 g	0,01 g / 0,1 g	0,1 g	0,1 g	1 g
Tare range	-0,2 kg	-0,6 kg	-2 kg	-6 kg	-10 kg	-10 kg	-20 kg	-21 kg
Repeatability	0,0014 g	0,008 g	0,015 g	0,1 g	0,015 g / 0,08 g	0,08 g	0,1 g	0,8 g
Linearity	±0,003 g	±0,03 g	±0,03 g	±0,3 g	±0,03 g / ±0,3 g	±0,3 g	±0,3 g	±3 g
Stabilization time	2 s	2 s	2 s	2 s	~ 4 s / 2 s	2 s	3 s	3 s
Pan size	Ø 100 mm	128 × 128 mm	195 × 195 mm					
Working temperature	+10° + +40 °C							
Power supply	12 ÷ 16 V DC							
Adjustment	external							
IP rating	IP 43							
Display	5" colour capacitive touchscreen							
Interfaces	2×RS232, USB-A, USB-B, Wireless Module							
Database	7 databases							
Net weight / Gross weight	1,8 kg / 3,4 kg	2,2 kg / 3,8 kg						
Packaging dimensions	470 × 380 × 336 mm							

\* Repeatability is expressed as a standard deviation from 10 weighing cycles

## Dimensions:

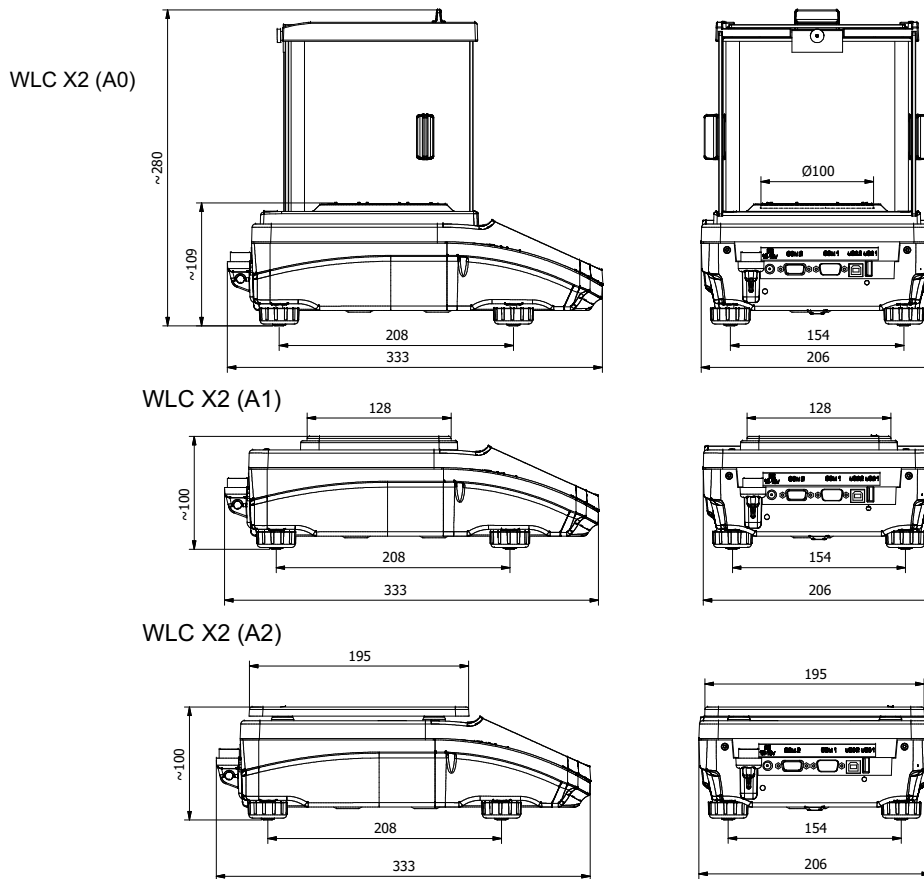

## Accessories:

Antivibration table for laboratory balances	Bar code scanner USB HID
Antivibration table SAL/STONE	Power loop output AP2-1 (plastic housing)
Impact printer Epson, Printer USB PCL	Additional LCD display "WD-6"
Density determination kit	Power adapter with battery and charger ZR-02
Rack for under hook weighing	Mass standard
"Tare" or "Print" foot button	USB A- USB B cable (balance - computer, balance - PLC printer)
PC keyboard USB	Cable RS 232 (scale - computer) "P0108"
External USB memory (FAT files format)	Cable RS 232 (scale, Epson printer) "P0151"
Bar code scanner	"PW-WIN", "RAD-KEY" computer software